

# Lift and transport truck HTW 50/100



The lift- and transport truck has a rugged, torsion-resistant frame structure, steel powder-coated (grey – RAL 9007) with smoothly running, integrated hydraulic unit for foot-actuated vertical adjustment for easy handling. 4 steerable solid rubber wheels, 2 of them lockable, 1 enabling locking as regards to the direction, d = 125 mm with special roller bearings, permanently lubricated and maintenance-free, which ensure an absolutely noiseless movement. A stainless steel roller track comprising 5 carrying rollers of corrosion-resistant material and plastic coating has been arranged on top of the truck. A holding device secures the body tray or coffin plate lying on it. The slide handle of the lift and transport truck can be removed. An anti-collision buffer is mounted to the front end. The low deadweight permits straightforward shunting and operation of the lift and transport truck. A special valve ensures even lowering at various loads.

## **Technical Data:**

Dimensions lowest Position W/D/H:	2150 x 750 x 300 mm
Dimensions highest Position W/D/H:	2150 x 750 x 1650 mm
Carrying capacity:	max. 250 kg
Dead weight:	approx. 100 kg
Material:	Steel
Colour:	Light grey RAL 9007 (powder coated)
Type:	HTW 50/100
Article No.:	050.010.010

*Additional models see back page*

**KUGEL medical GmbH & Co. KG**  
Hermann-Köhl-Str. 2A  
DE - 93049 Regensburg / GERMANY

Phone +49/9 41/20 86 48-0  
Fax +49/9 41/20 86 48-29  
[www.KUGEL-medical.de](http://www.KUGEL-medical.de)



**KUGEL**  
medical  
■ ■ ■ ■

# Stainless steel lift and transport truck HTW 51/100

The lift- and transport truck has a rugged, torsion-resistant frame structure, completely made of stainless steel (Material no. 1.4301 – ANSI 304) with smoothly running, integrated hydraulic unit for foot-actuated vertical adjustment for easy handling. 4 steerable solid rubber wheels, 2 of them lockable, 1 enabling locking as regards to the direction,  $d = 125$  mm with special roller bearings, permanently lubricated and maintenance-free, which ensure an absolutely noiseless movement. A stainless steel roller track comprising 5 carrying rollers of corrosion-resistant material and plastic coating has been arranged on top of the truck. A holding device secures the body tray or coffin plate lying on it. The slide handle of the lift and transport truck can be removed. An anti-collision buffer is mounted to the front end.

## **Technical Data:**

Dimensions lowest Position W/D/H:	2150 x 750 x 300 mm
Dimensions highest Position W/D/H:	2150 x 750 x 1650 mm
Carrying capacity:	max. 250 kg
Dead weight:	approx. 100 kg
Material:	Stainless steel (Material No. 1.4301 – ANSI 304)
Type:	HTW 51/100
Article No.:	050.090.010

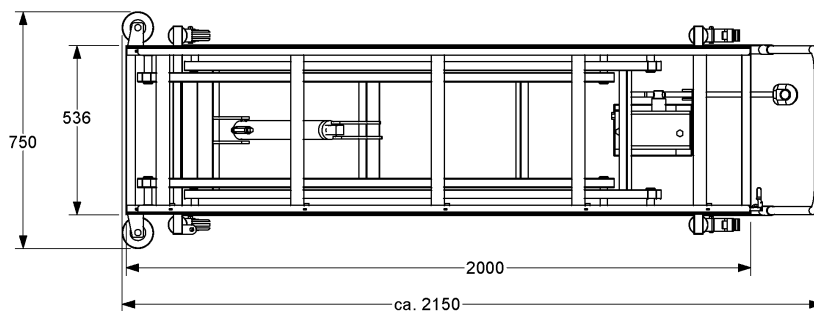
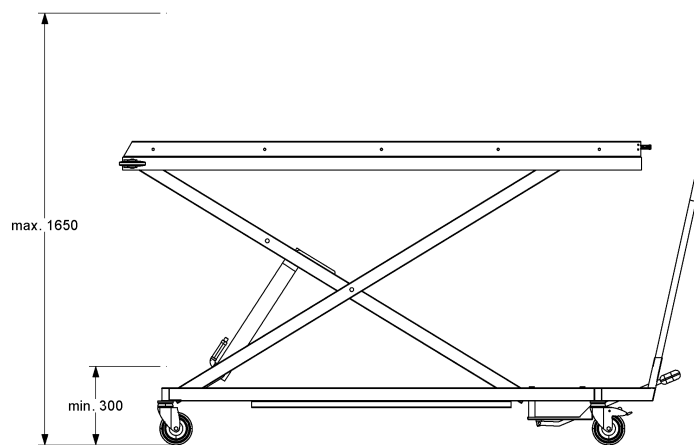

**KUGEL medical GmbH & Co. KG**  
Hermann-Köhl-Str. 2A  
DE - 93049 Regensburg / GERMANY

Phone +49/9 41/20 86 48-0  
Fax +49/9 41/20 86 48-29  
[www.KUGEL-medical.de](http://www.KUGEL-medical.de)



**KUGEL**  
medical  
■ ■ ■ ■